

Review of Lecture 9

- Logistic regression

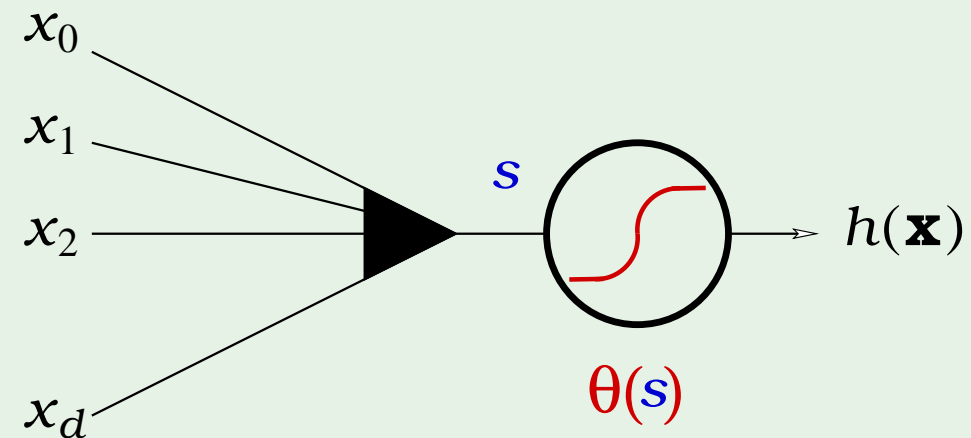

- Likelihood measure

$$\prod_{n=1}^N P(y_n | \mathbf{x}_n) = \prod_{n=1}^N \theta(y_n \mathbf{w}^T \mathbf{x}_n)$$

- Gradient descent

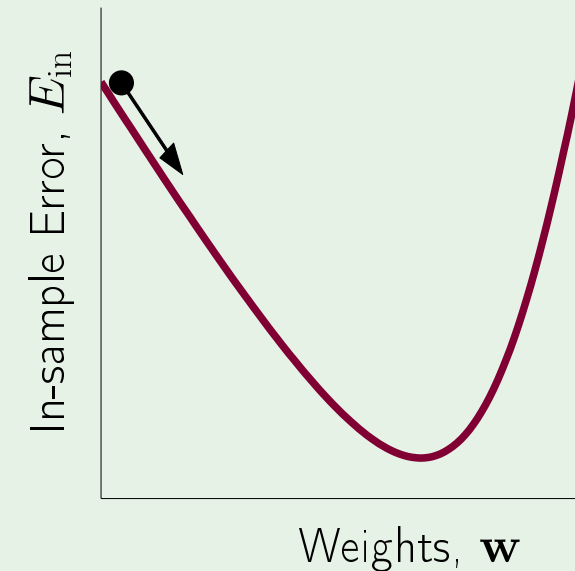

- Initialize $\mathbf{w}(0)$

- For $t = 0, 1, 2, \dots$ [to termination]

$$\mathbf{w}(t + 1) = \mathbf{w}(t) - \eta \nabla E_{in}(\mathbf{w}(t))$$

- Return final \mathbf{w}

Learning From Data

Yaser S. Abu-Mostafa
California Institute of Technology

Lecture 10: **Neural Networks**



Sponsored by Caltech's Provost Office, E&AS Division, and IST • Thursday, May 3, 2012

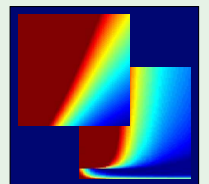

Outline

- Stochastic gradient descent
- Neural network model
- Backpropagation algorithm

Stochastic gradient descent

GD minimizes:

$$E_{\text{in}}(\mathbf{w}) = \frac{1}{N} \sum_{n=1}^N \underbrace{e(h(\mathbf{x}_n), y_n)}_{\ln(1+e^{-y_n \mathbf{w}^T \mathbf{x}_n})} \leftarrow \text{in logistic regression}$$

by iterative steps along $-\nabla E_{\text{in}}$:

$$\Delta \mathbf{w} = -\eta \nabla E_{\text{in}}(\mathbf{w})$$

∇E_{in} is based on all examples (\mathbf{x}_n, y_n)

“batch” GD

The stochastic aspect

Pick one (\mathbf{x}_n, y_n) at a time. Apply GD to $\mathbf{e}(h(\mathbf{x}_n), y_n)$

“Average” direction:

$$\begin{aligned}\mathbb{E}_n \left[-\nabla \mathbf{e}(h(\mathbf{x}_n), y_n) \right] &= \frac{1}{N} \sum_{n=1}^N -\nabla \mathbf{e}(h(\mathbf{x}_n), y_n) \\ &= -\nabla E_{\text{in}}\end{aligned}$$

randomized version of GD

stochastic gradient descent (SGD)

Benefits of SGD

1. cheaper computation
2. randomization
3. simple

Rule of thumb:

$$\eta = 0.1 \text{ works}$$

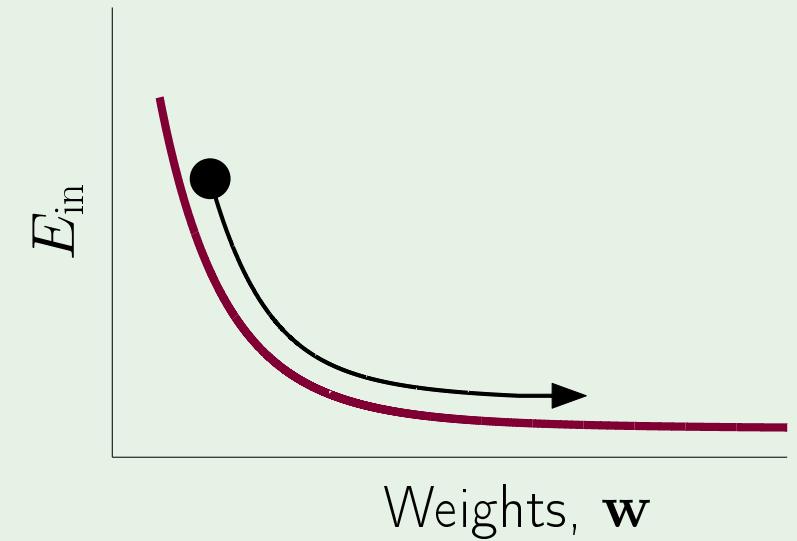
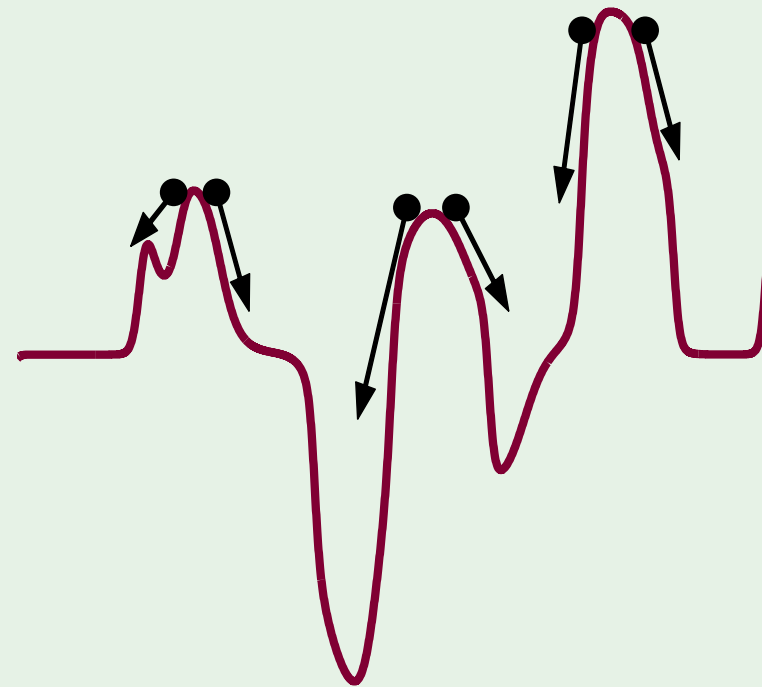

randomization helps

SGD in action

Remember movie ratings?

$$e_{ij} = \left(r_{ij} - \sum_{k=1}^K u_{ik} v_{jk} \right)^2$$

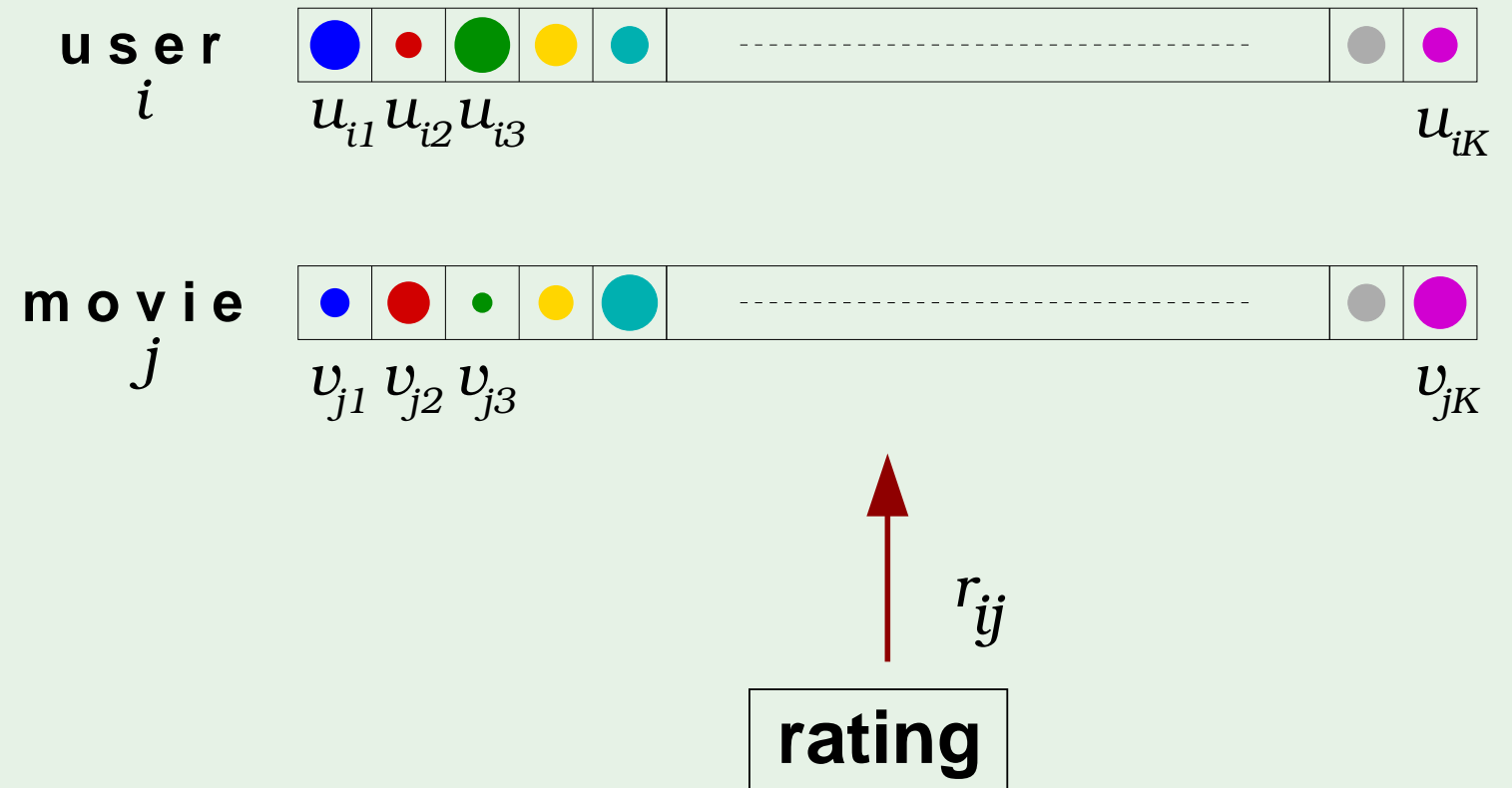

Outline

- Stochastic gradient descent
- Neural network model
- Backpropagation algorithm

Biological inspiration

biological function

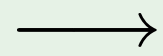

biological structure

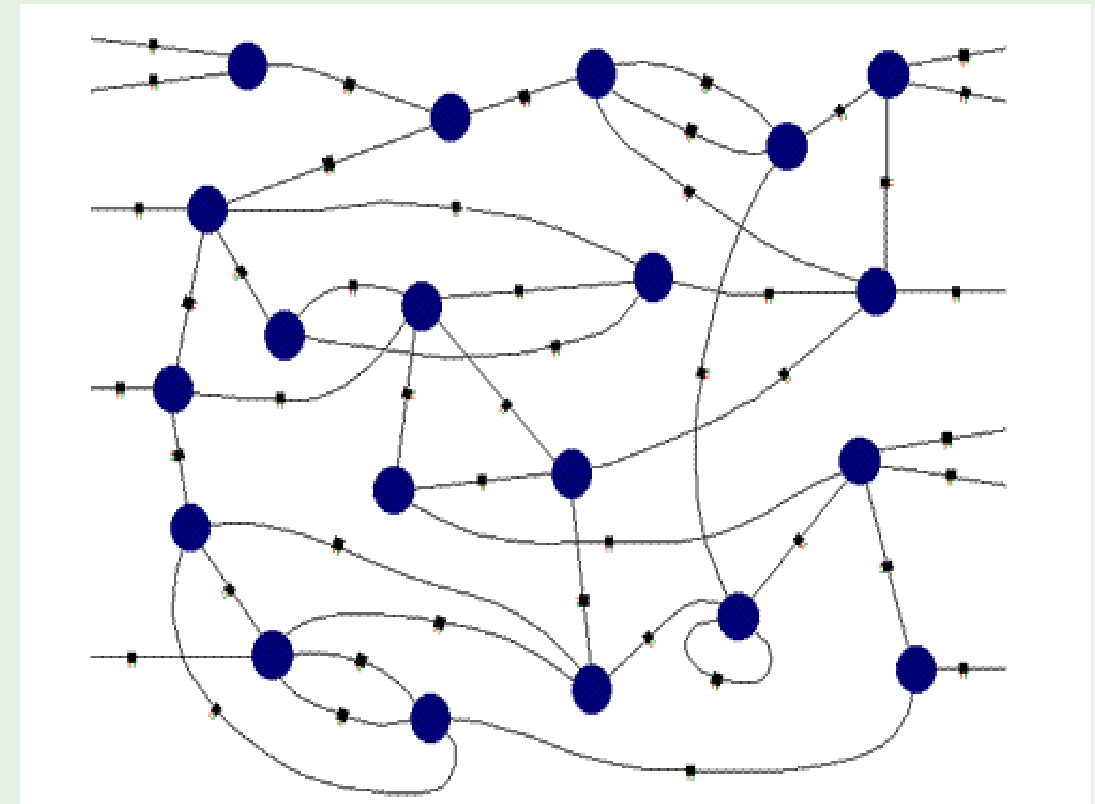
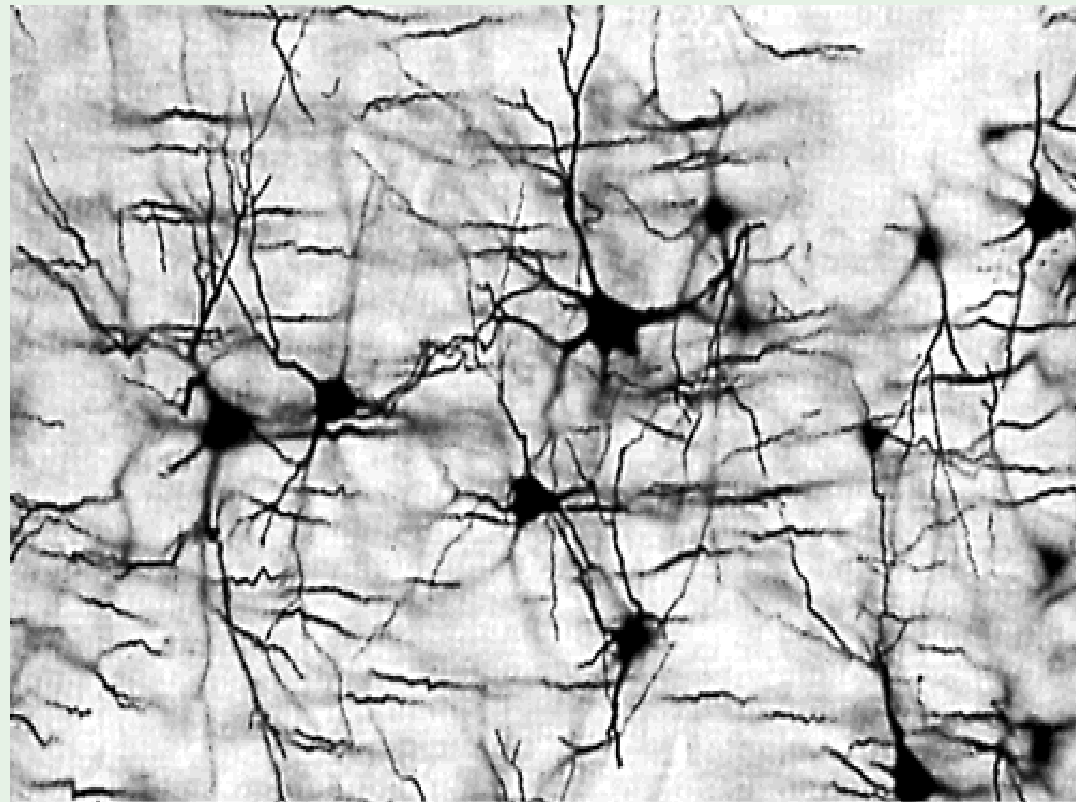

Combining perceptrons

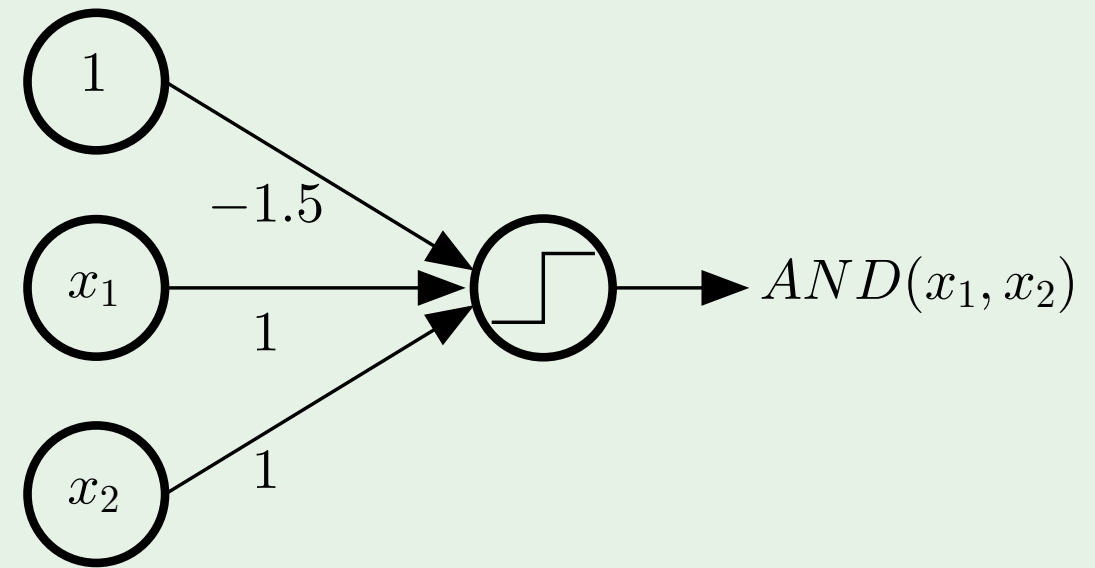
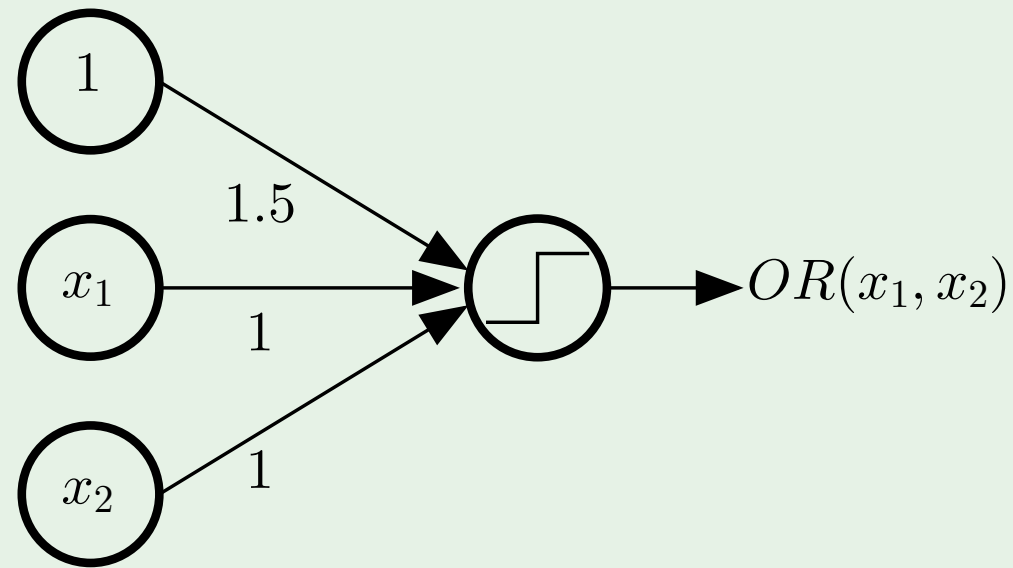
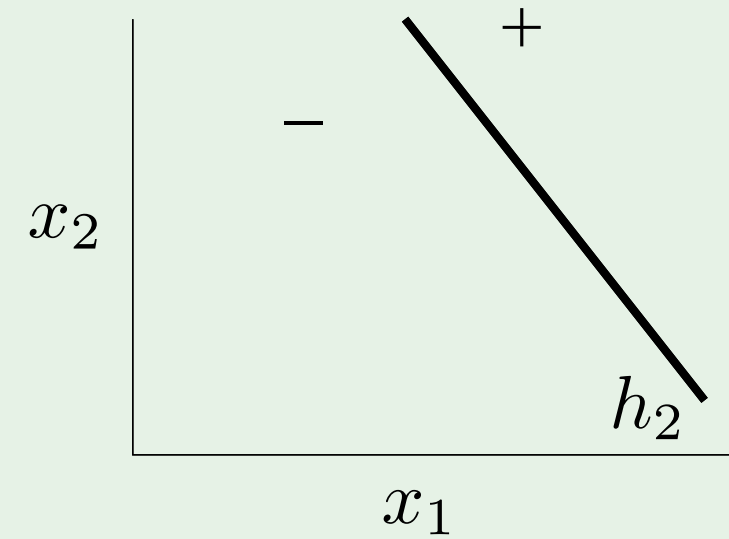
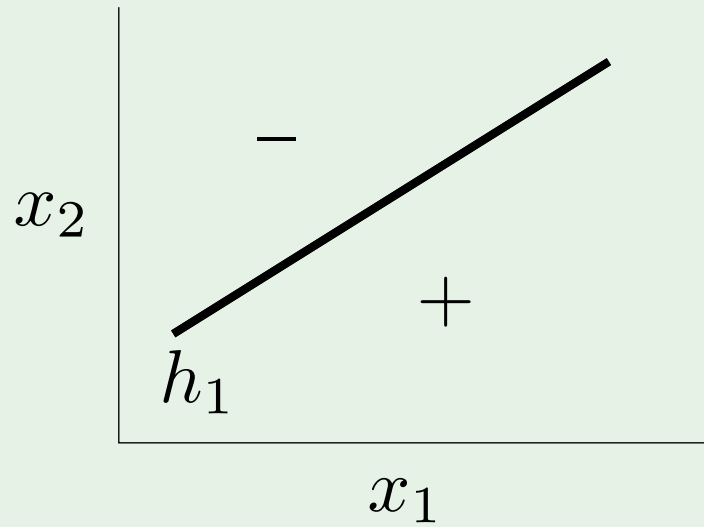
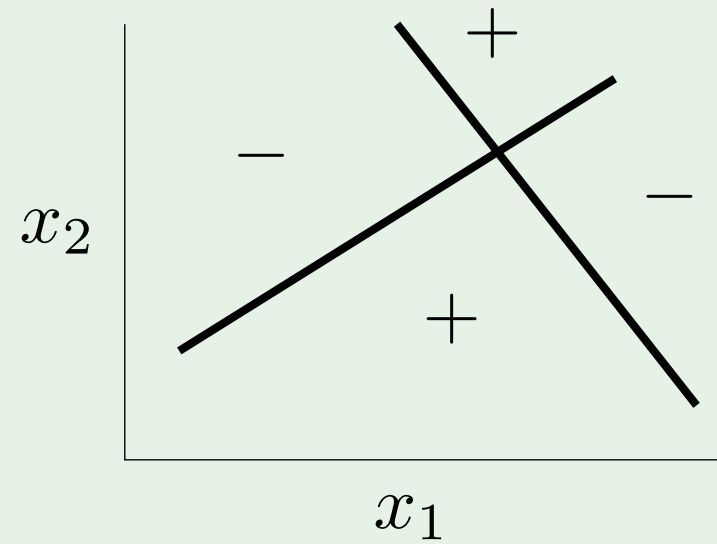

Creating layers

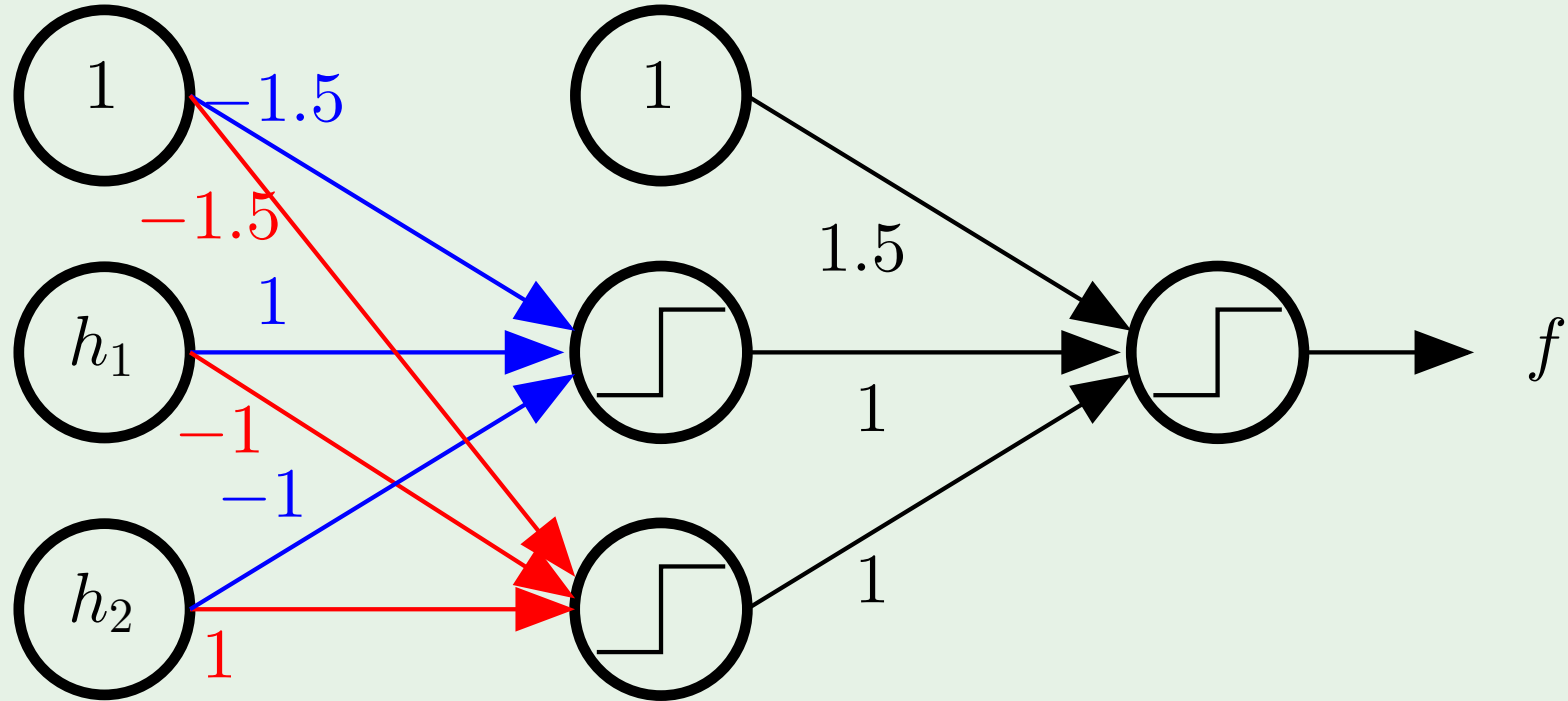
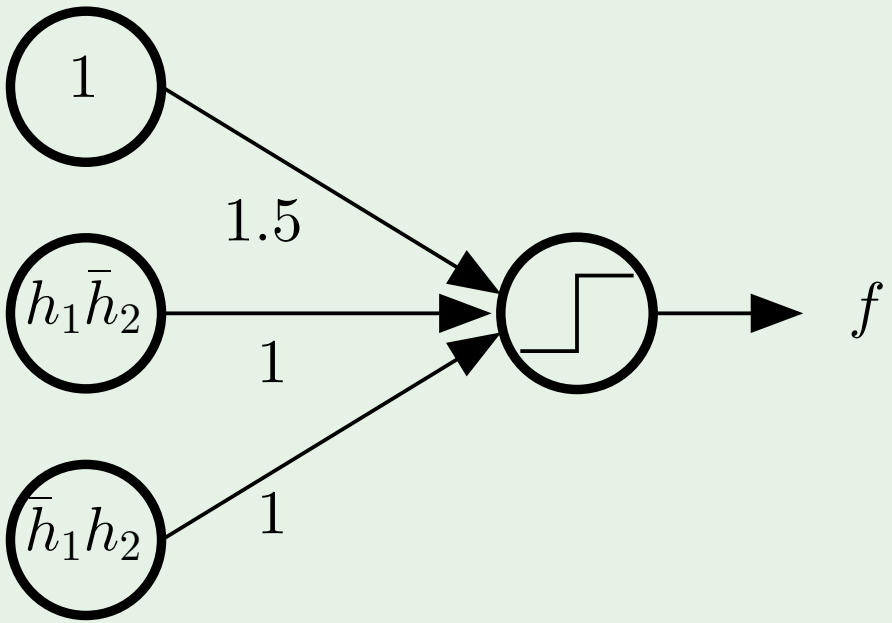

The multilayer perceptron

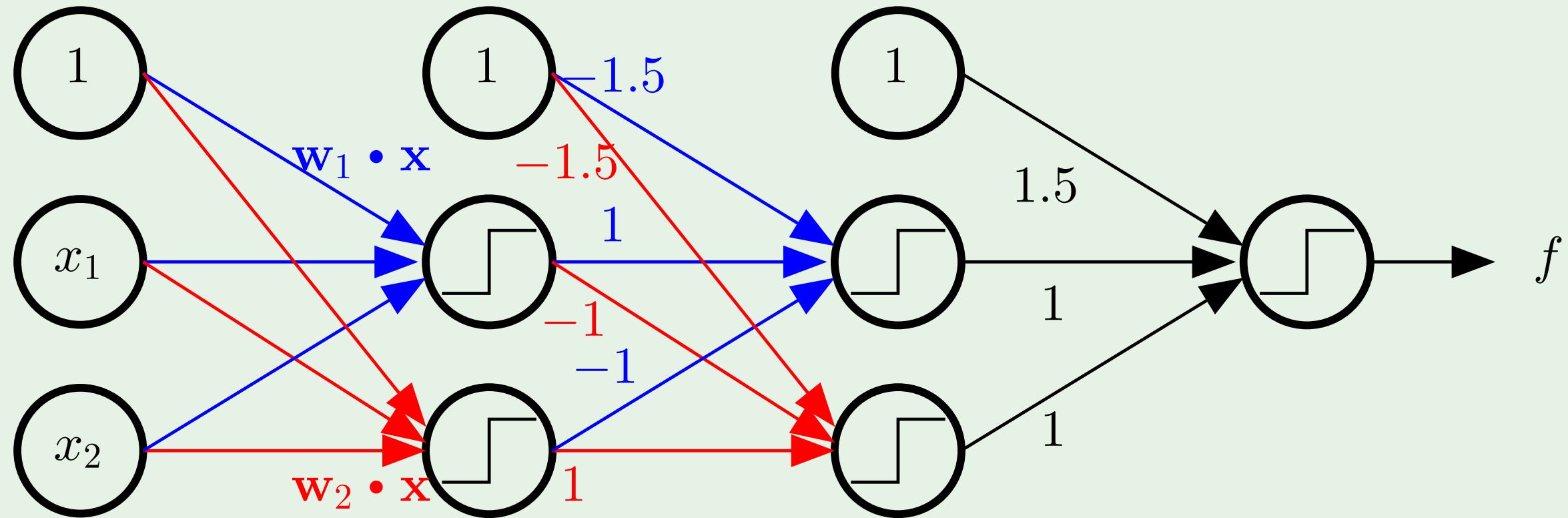

3 layers “feedforward”

A powerful model

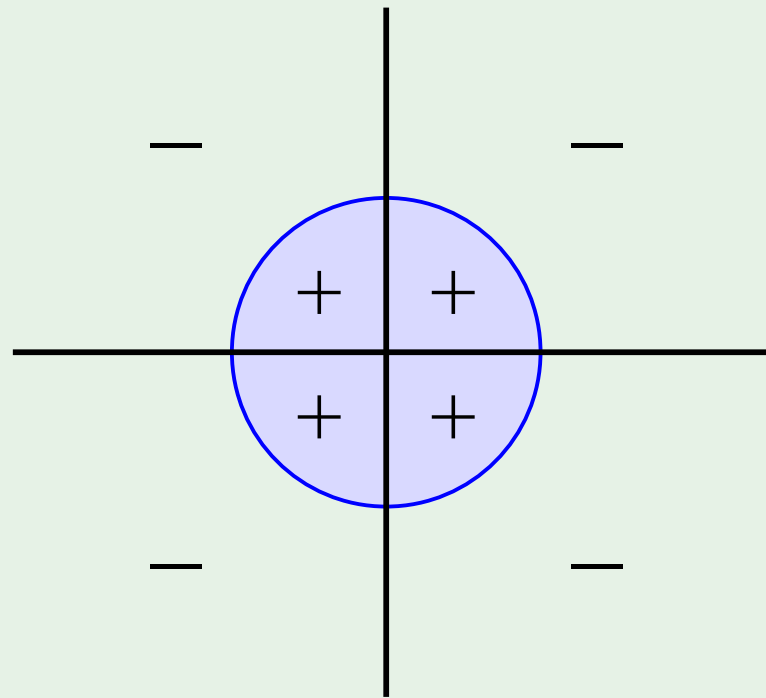

Target

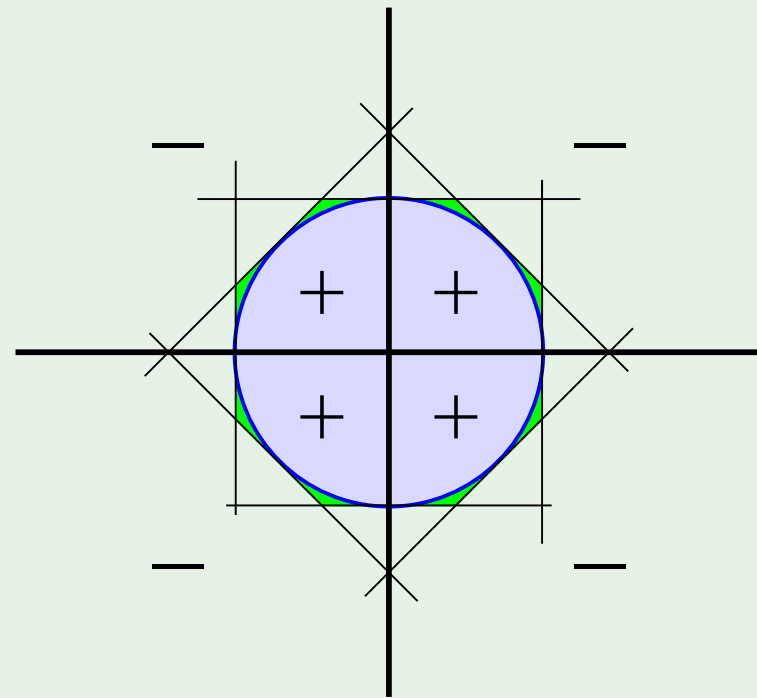

8 perceptrons

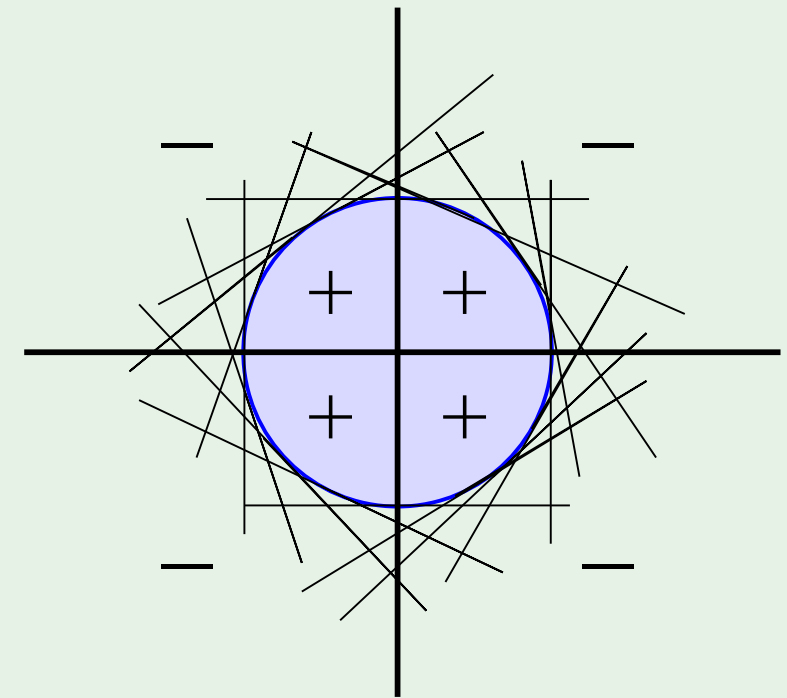

16 perceptrons

2 red flags for **generalization** and **optimization**

The neural network

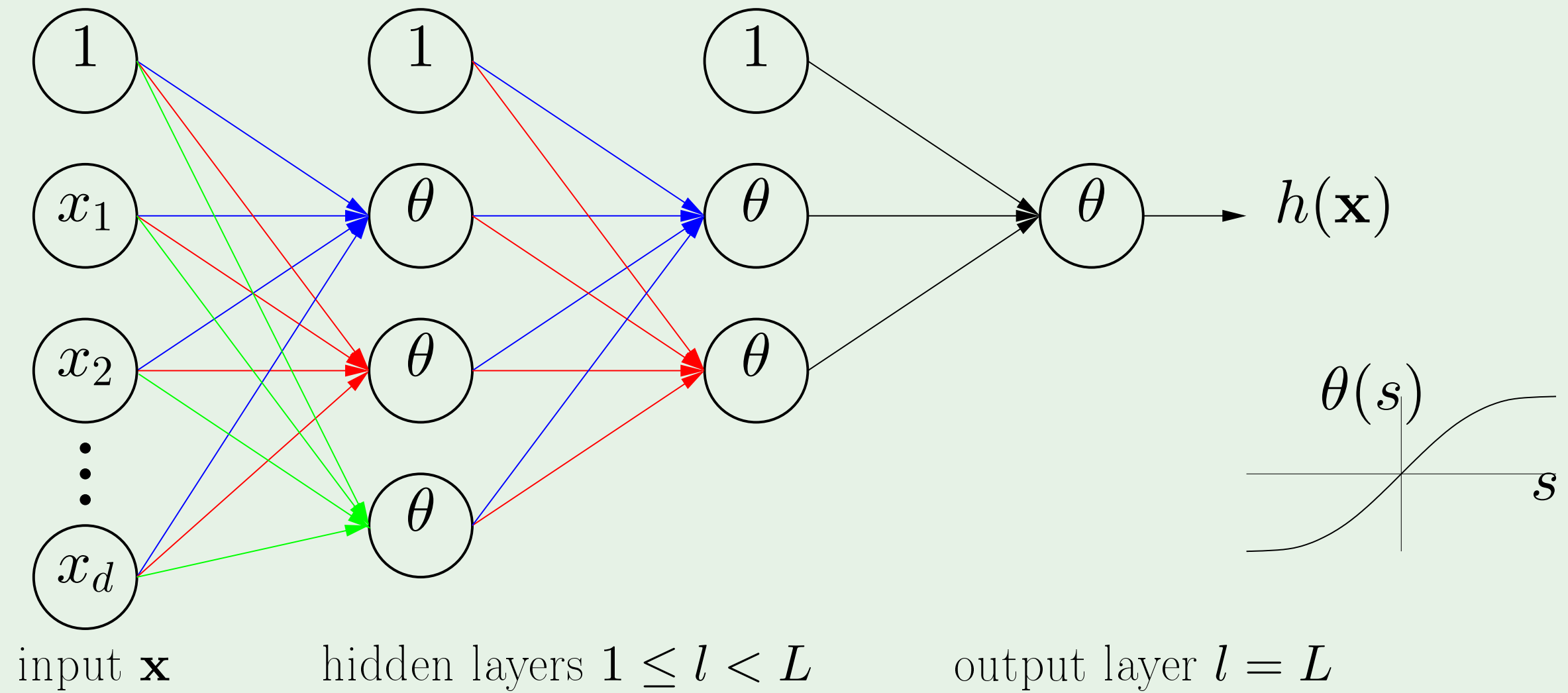

How the network operates

$$w_{ij}^{(l)} \begin{cases} 1 \leq l \leq L & \text{layers} \\ 0 \leq i \leq d^{(l-1)} & \text{inputs} \\ 1 \leq j \leq d^{(l)} & \text{outputs} \end{cases}$$

$$x_j^{(l)} = \theta(s_j^{(l)}) = \theta \left(\sum_{i=0}^{d^{(l-1)}} w_{ij}^{(l)} x_i^{(l-1)} \right)$$

Apply \mathbf{x} to $x_1^{(0)} \cdots x_{d^{(0)}}^{(0)} \rightarrow \rightarrow x_1^{(L)} = h(\mathbf{x})$

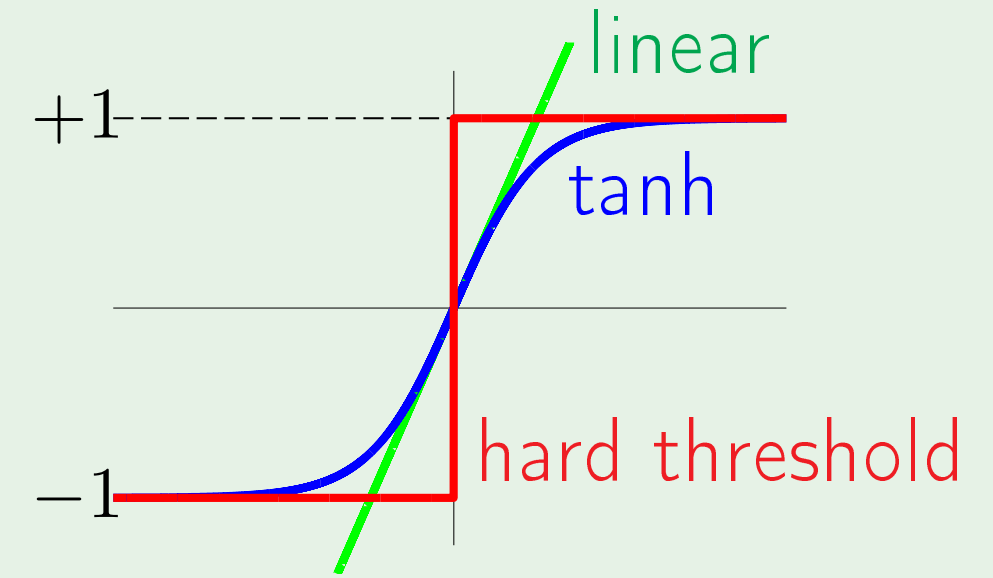

$$\theta(s) = \tanh(s) = \frac{e^s - e^{-s}}{e^s + e^{-s}}$$

Outline

- Stochastic gradient descent
- Neural network model
- Backpropagation algorithm

Applying SGD

All the weights $\mathbf{w} = \{w_{ij}^{(l)}\}$ determine $h(\mathbf{x})$

Error on example (\mathbf{x}_n, y_n) is

$$e(h(\mathbf{x}_n), y_n) = e(\mathbf{w})$$

To implement SGD, we need the gradient

$$\nabla e(\mathbf{w}): \frac{\partial e(\mathbf{w})}{\partial w_{ij}^{(l)}} \text{ for all } i, j, l$$

Computing $\frac{\partial e(\mathbf{w})}{\partial w_{ij}^{(l)}}$

We can evaluate $\frac{\partial e(\mathbf{w})}{\partial w_{ij}^{(l)}}$ one by one: analytically or numerically

A trick for efficient computation:

$$\frac{\partial e(\mathbf{w})}{\partial w_{ij}^{(l)}} = \frac{\partial e(\mathbf{w})}{\partial s_j^{(l)}} \times \frac{\partial s_j^{(l)}}{\partial w_{ij}^{(l)}}$$

We have $\frac{\partial s_j^{(l)}}{\partial w_{ij}^{(l)}} = x_i^{(l-1)}$

We only need: $\frac{\partial e(\mathbf{w})}{\partial s_j^{(l)}} = \delta_j^{(l)}$

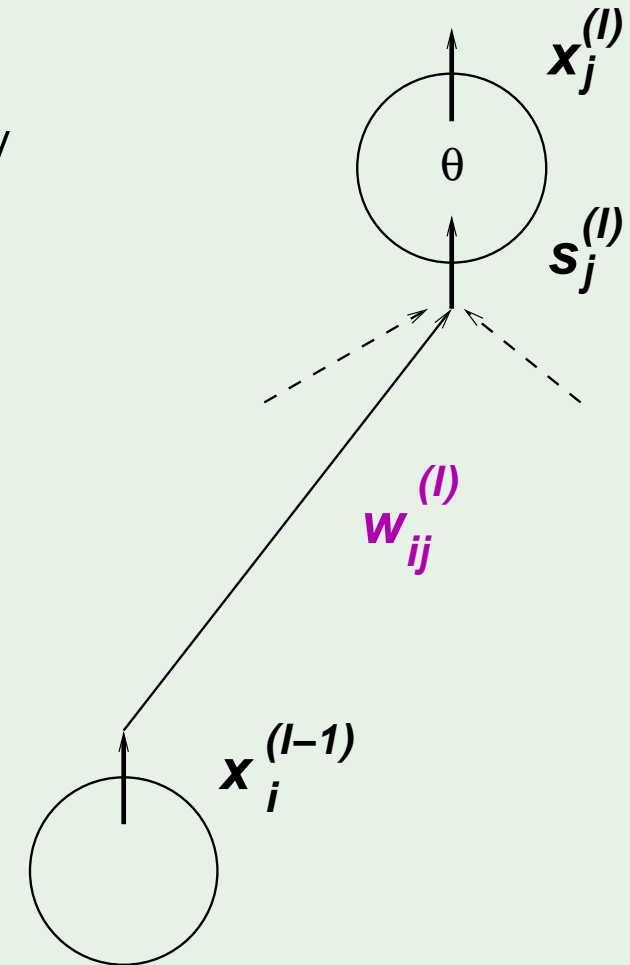

δ for the final layer

$$\delta_j^{(l)} = \frac{\partial e(\mathbf{w})}{\partial s_j^{(l)}}$$

For the final layer $l = L$ and $j = 1$:

$$\delta_1^{(L)} = \frac{\partial e(\mathbf{w})}{\partial s_1^{(L)}}$$

$$e(\mathbf{w}) = (x_1^{(L)} - y_n)^2$$

$$x_1^{(L)} = \theta(s_1^{(L)})$$

$$\theta'(s) = 1 - \theta^2(s) \quad \text{for the tanh}$$

Back propagation of δ

$$\begin{aligned}
 \delta_i^{(l-1)} &= \frac{\partial e(\mathbf{w})}{\partial s_i^{(l-1)}} \\
 &= \sum_{j=1}^{d^{(l)}} \frac{\partial e(\mathbf{w})}{\partial s_j^{(l)}} \times \frac{\partial s_j^{(l)}}{\partial x_i^{(l-1)}} \times \frac{\partial x_i^{(l-1)}}{\partial s_i^{(l-1)}} \\
 &= \sum_{j=1}^{d^{(l)}} \delta_j^{(l)} \times w_{ij}^{(l)} \times \theta'(s_i^{(l-1)}) \\
 \delta_i^{(l-1)} &= (1 - (x_i^{(l-1)})^2) \sum_{j=1}^{d^{(l)}} w_{ij}^{(l)} \delta_j^{(l)}
 \end{aligned}$$

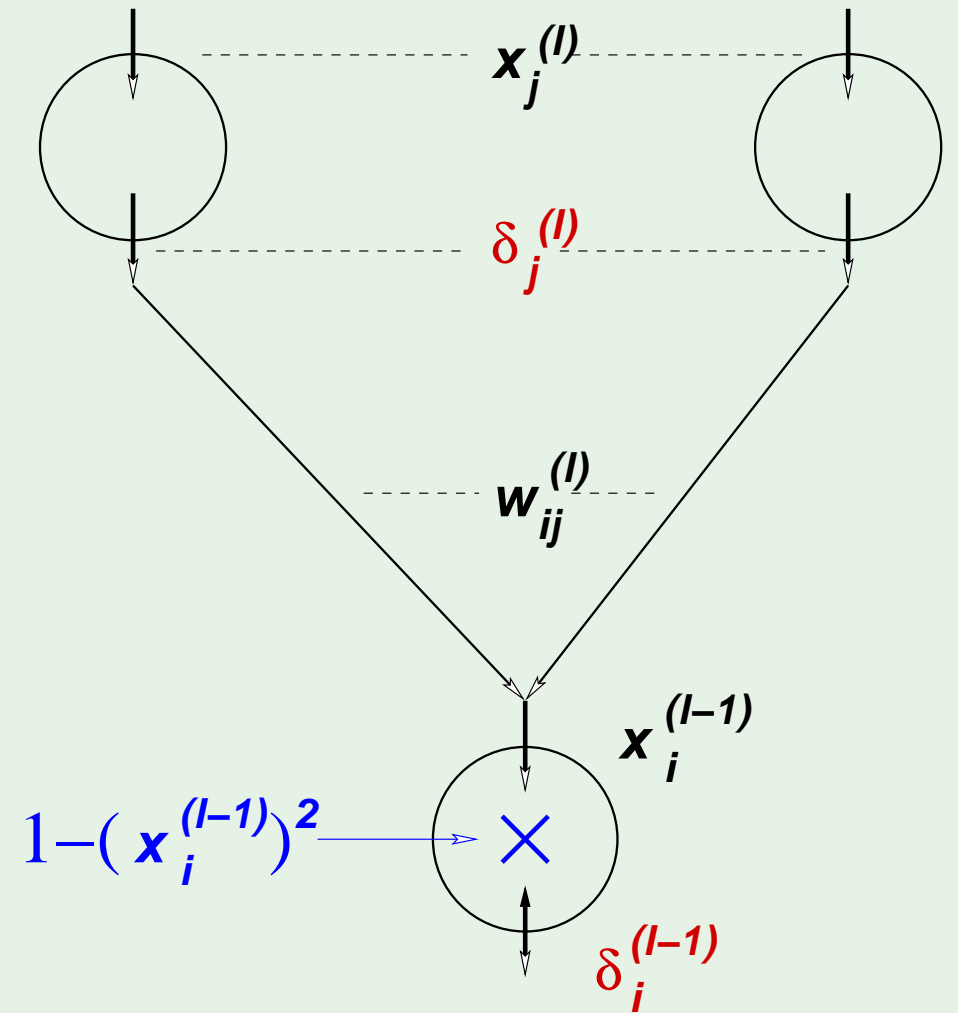

Backpropagation algorithm

- 1: Initialize all weights $w_{ij}^{(l)}$ **at random**
- 2: **for** $t = 0, 1, 2, \dots$ **do**
- 3: Pick $n \in \{1, 2, \dots, N\}$
- 4: *Forward:* Compute all $x_j^{(l)}$
- 5: *Backward:* Compute all $\delta_j^{(l)}$
- 6: Update the weights: $w_{ij}^{(l)} \leftarrow w_{ij}^{(l)} - \eta x_i^{(l-1)} \delta_j^{(l)}$
- 7: Iterate to the next step until it is time to stop
- 8: Return the final weights $w_{ij}^{(l)}$

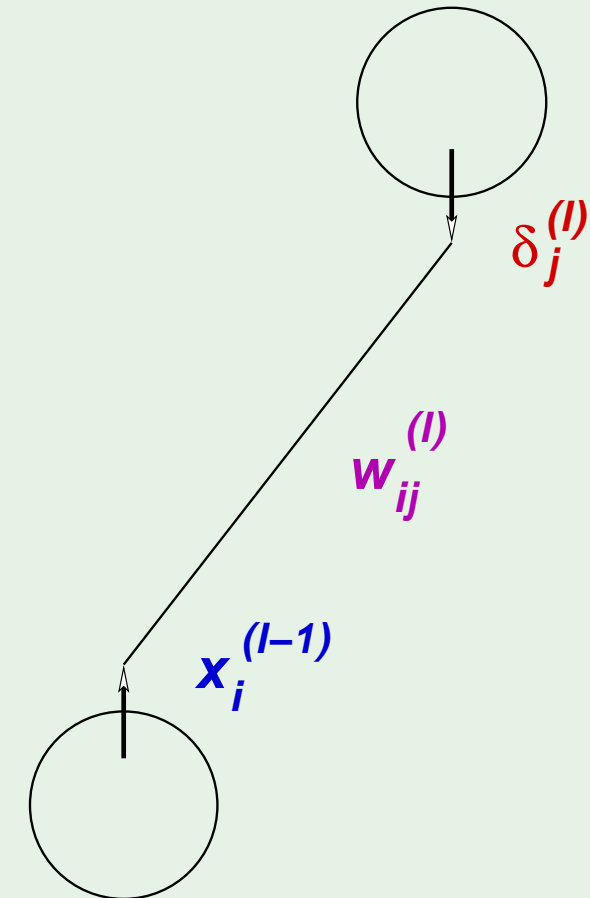

Final remark: hidden layers

learned nonlinear transform

interpretation?

